

Mounting plates

Type	Application	Order No.
Size 1	Wall mounting	GHG 610 1953 R0101
Size 1	Trellis mounting	GHG 610 1953 R0103
Size 1	Pipe mounting	GHG 610 1953 R0102
Size 2	Wall mounting	GHG 610 1953 R0104
Size 2	Trellis mounting	GHG 610 1953 R0106
Size 2	Pipe mounting	GHG 610 1953 R0105
Size 2A	Wall mounting	GHG 610 1953 R0107
Size 2A	Trellis mounting	GHG 610 1953 R0109
Size 2A	Pipe mounting	GHG 610 1953 R0108
Size 3	Wall mounting	GHG 610 1953 R0118
Size 3	Trellis mounting	GHG 610 1953 R0118
Size 3	Pipe mounting	GHG 610 1953 R0110
Size 4	Wall mounting	GHG 610 1953 R0126
Size 4	Trellis mounting	GHG 610 1953 R0126
Size 4	Pipe mounting	GHG 610 1953 R0130
Size 5	Wall mounting	GHG 610 1953 R0128
Size 5	Trellis mounting	GHG 610 1953 R0128
Size 5	Pipe mounting	GHG 610 1953 R0132

| Fitting materials and accessories |

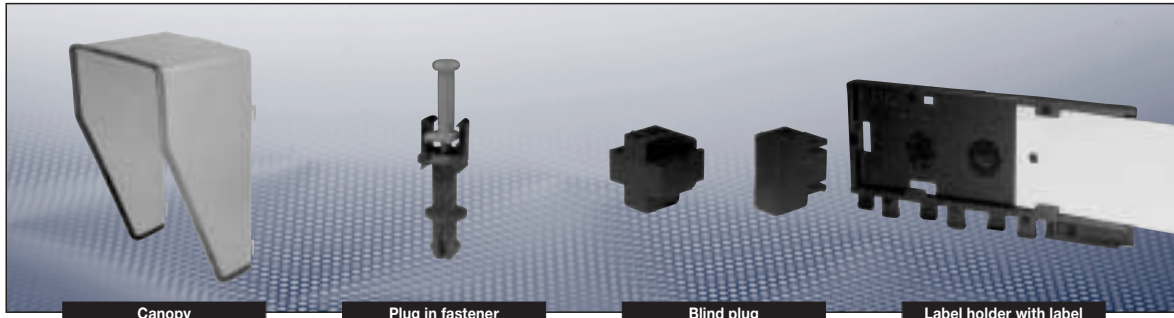

Accessories

For mounting plate

Type	OU	Order No.
Label holder with type label (blank) for mounting plates size 1, 2, 2A and 3	10	GHG 610 1953 R0057
Type label for label holder and mounting plates size 4 and size 5	10	GHG 610 1953 R0011
Blind plug for unused fixing points of mounting plates size 4 and size 5	10	GHG 610 1953 R0134
Plug-in fastener for CEAG modules with 5.5 mm and 11 mm fixing elements 1 set = 4 pcs.	10	GHG 610 1953 R0041
Mounting set for pipes 1" (Ø 27 - 30 mm) for mounting plates with pipe fixing	10	GHG 610 1953 R0020

The order No. will show 1 pcs.

Please note that only pack quantities (OU) can be ordered.

Protective canopy for mounting plate

Type	Application	Order No.
Size 1	for mounting plate size 1	GHG 610 1955 R0101
Size 2	for mounting plate size 2	GHG 610 1955 R0102
Size 2A	for mounting plate size 2A	GHG 610 1955 R0103
Size 3	for mounting plates pipe fixing size 3 vertically	GHG 610 1955 R0104
Size 3A	for mounting plates wall/trellis fixing size 3 vertically	GHG 610 1955 R0105
Size 3B	for mounting plates pipe fixing size 3 horizontal	GHG 610 1955 R0106
Size 4	for mounting plate size 4	GHG 610 1955 R0107
Size 5	for mounting plate size 5	GHG 610 1955 R0108

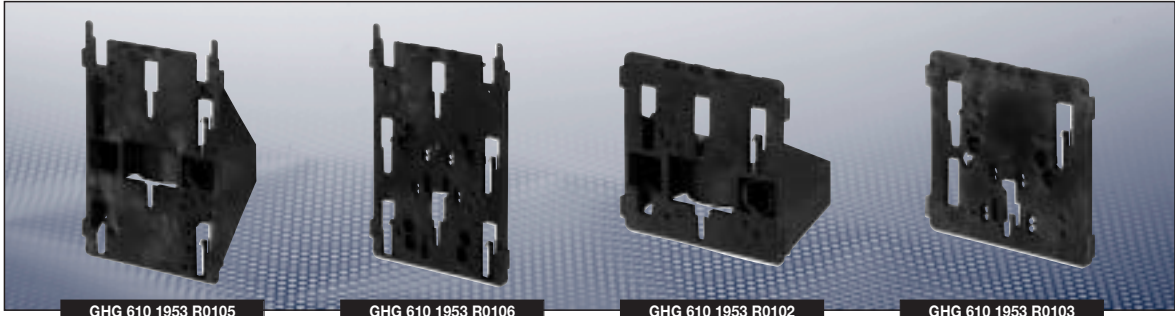

Dimensions

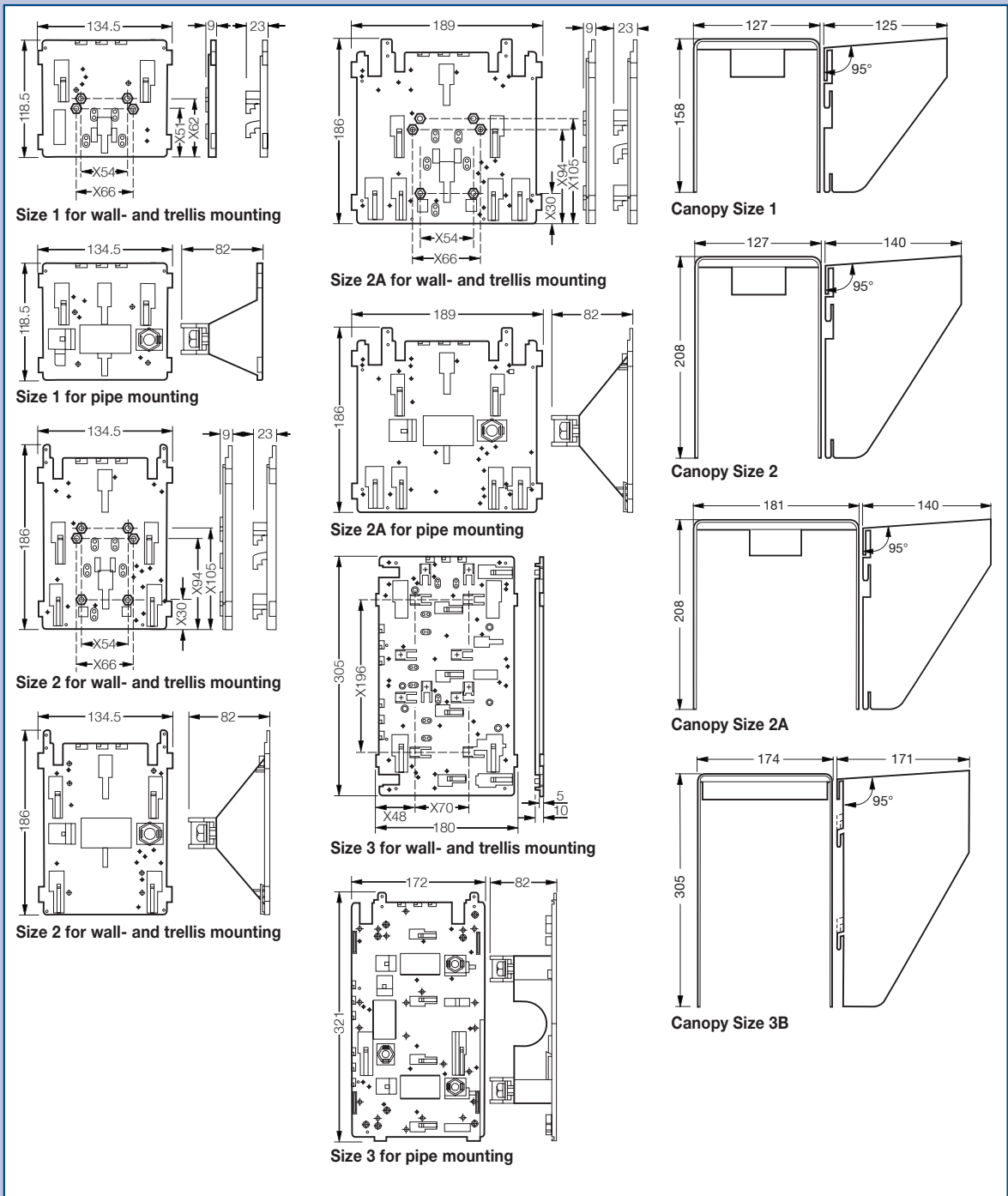

Dimensions in mm

1
2
3
4
5
6
7
8
9
10
11
12

| Fitting materials and accessories |

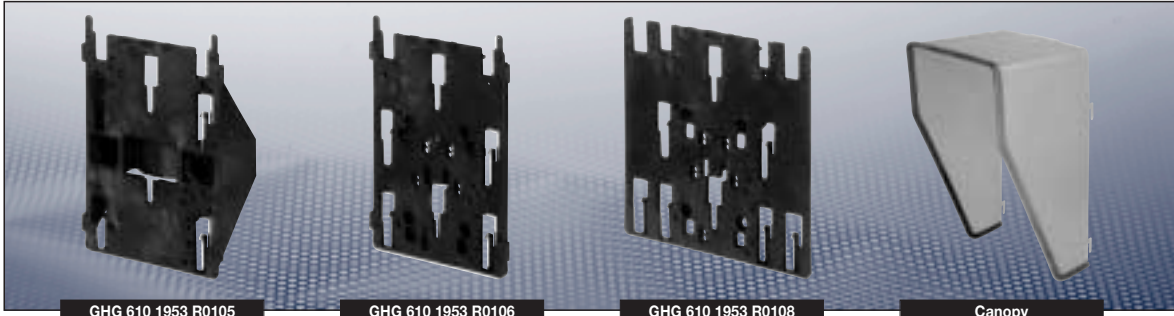

GHG 610 1953 R0105

GHG 610 1953 R0106

GHG 610 1953 R0108

Canopy

Dimensions

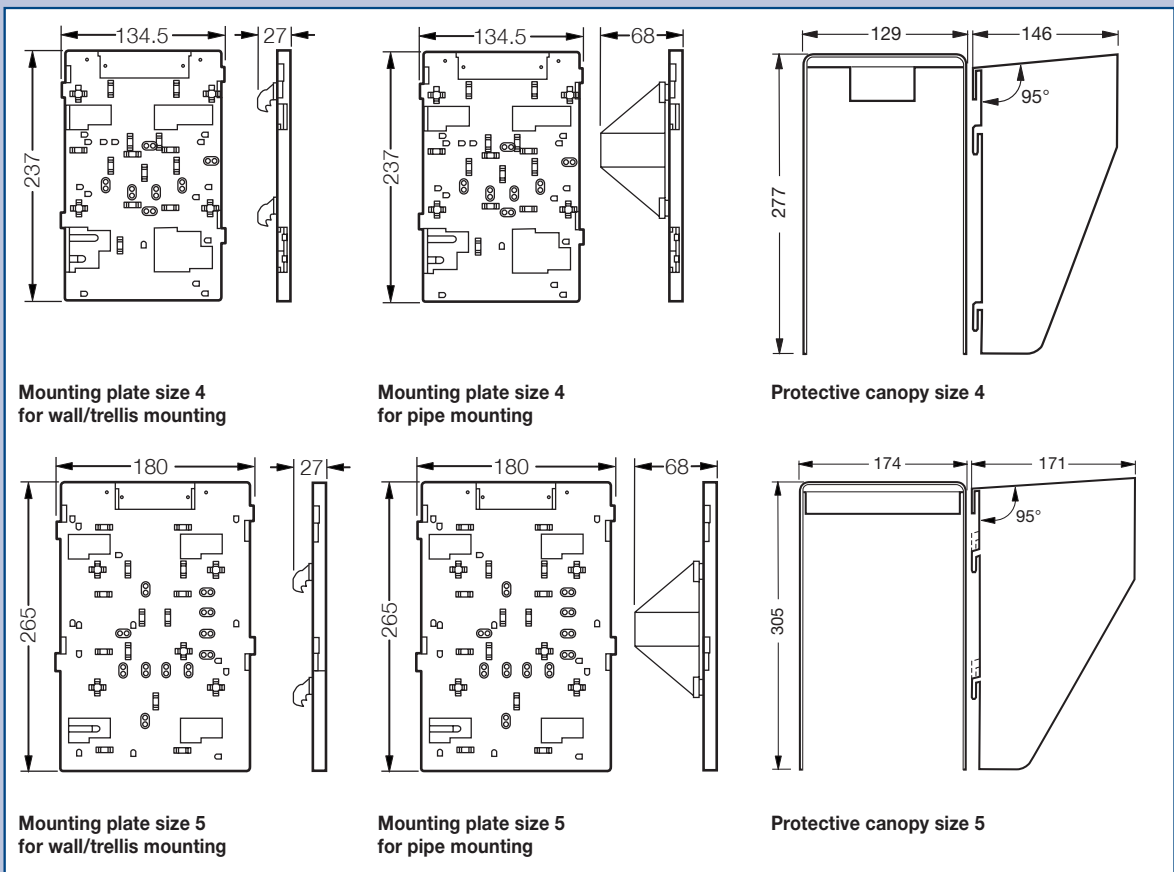

Dimensions in mm