

## Ordering details



Type	Scope of delivery	Order unit	Order No.
TX 40 + CX 40	TX 40 for zone 0 with battery and LED, with inductive charger CX 40 for zone 1	1	<b>1 1380 000 003</b>



3 x TX 20 + 1 x CX 20 charger	TX 20 for zone 0 with battery and LED, with inductive charger CX 20 for zone 1	1	<b>1 1380 000 022</b>
-------------------------------	--	---	-----------------------

## Accessories



Type	Scope of delivery	details	Order unit	Order No.
TX 40	with battery and LED without charger	certified for zone 0	1	<b>1 1380 000 001</b>



CX 40	inductive charger with 2 m line cord	certified for zone 1 charger for 1 x TX 40	1	<b>1 1380 000 002</b>
-------	--------------------------------------	---	---	-----------------------



TX 20	with battery and LED without charger	certified for zone 0	1	<b>1 1380 000 020</b>
-------	--------------------------------------	----------------------	---	-----------------------



CX 20	inductive charger with 2 m line cord	certified for zone 1, charger for 3 x TX 20	1	<b>1 1380 000 021</b>
-------	--------------------------------------	--	---	-----------------------

# 1.3

## Dimension drawing / Range-diagram

Ex-Lighting systems TX/CX 20 and TX/CX 40

Range-diagram TX 20

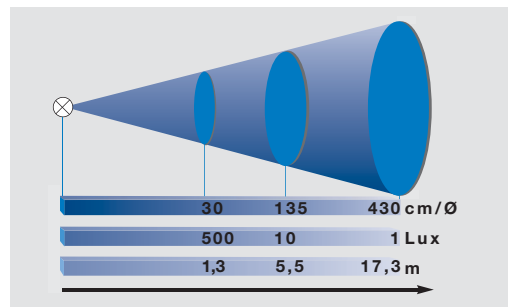

Dimension drawing TX 20

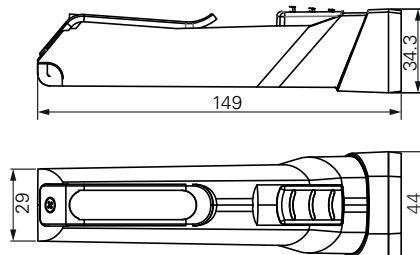

Range-diagram TX 40

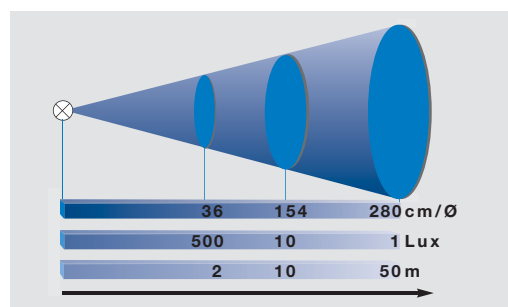

Dimension drawing CX 20

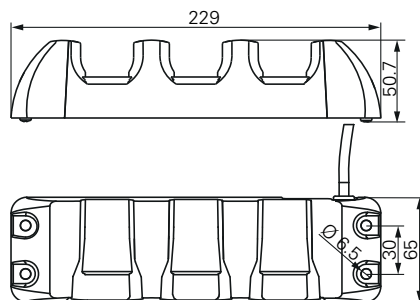

Dimension drawing TX 40

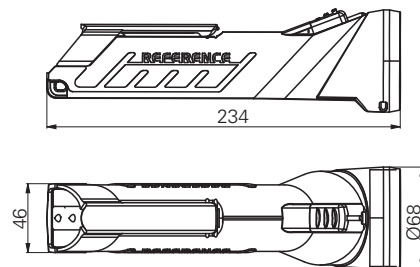

Dimension drawing CX 40

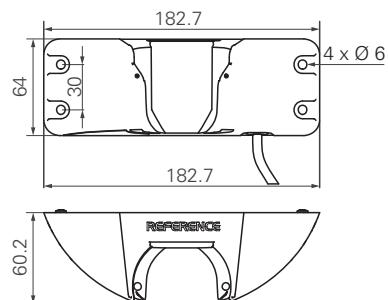

Dimensions in mm



### Technical data

	Torch TX 20	Torch TX 40
EC-Type Examination Certificate	DNV-11-ATEX-99371	DNV-2008-OLS-ATEX-38719
Marking accd. to 94/9/EC	⊕ II 1 G Ex ia [op is] IIC T4 Ga	⊕ II 1 G Ex ia IIC T 3
IECEx Certificate of Conformity	IECEx DNV 11.0009	IECEx DNV 08.0010
Permissible ambient temperature	-40 °C up to 60 °C	-40 °C up to 60 °C
Lamp	high efficiency LED, 3 W	high efficiency LED, 3 W
Luminous flux	114 lm	200 lm
Luminous intensity	approx. 550 cd	approx. 5.000 cd
Light aperture	Polycarbonate with 5° lens/hardened scratch resistant glass 3 mm	Polycarbonate with 4° lens/hardened scratch resistant glass 3 mm
Indication lamps	red and green LED	red and green LED
Degree of protection accd. to EN 60529	IP67	IP67
Enclosure material	plastic yellow/black	plastic yellow/black
Weight	0.13 kg	0.6 kg
Dimensions (L x W x H)	150 x 42 x 34 mm	230 x 70 x 70 mm
Operating time	approx. 5 h	approx. 5 h
Life expectancy	more than 1000 recharge cycles	more than 1000 recharge cycles



### Technical data

	Charger CX 20	Charger CX 40
EC-Type Examination Certificate	DNV-11-ATEX-99371	DNV-2008-OLS-ATEX-38719
Marking accd. to 94/9/EC	⊕ II 2 G Ex mb II T4 Gb	⊕ II 2 G Ex mb II T 4
IECEx Certificate of Conformity	IECEx DNV 11.0009	IECEx DNV 08.0010
Permissible ambient temperature	-40 °C up to 60 °C	-40 °C up to 60 °C
Rated voltage	100 - 250 V AC	100 - 250 V AC
Rated current	max. 1.0 A	max. 1.0 A
Frequency	50 - 60 Hz	50 - 60 Hz
Protection class	II	II
Charging duration	approx. 3 h (80% in 2 h)	approx. 3 h (80% in 2 h)
Degree of protection accd. to EN 60529	IP67	IP67
Standard cable length	2.0 m	2.0 m
Dimensions (L x W x H)	230 x 63 x 48 mm	185 x 65 x 60 mm
Weight	0.55 kg	0.6 kg